



Vibe LED Square Wall Light Surface Mount 3W Black 3K

VBLWL-103-4-3K



Vibe 100X series Weatherproof Black Square or Round Wall Lights are constructed from a high strength aluminium body and UV stabilised with Akzo Nobel polyester powder coating rendering them resistant to corrosive environments. Equipped with OSRAM LED chips, a 50,000 hour lifespan, a weatherproof rating of IP65 & backed by a 3 year warranty.

Features & Benefits

- Weatherproof and a high strength aluminium body
- Powder coating with UV resistance
- Equipped with OSRAM LED
- Built-in driver and easy to install
- 100° or 95° beam angle asymmetrical
- Available in round or square shape
- Anti-dazzle design provides better glare control
- 50,000 hour lifespan
- 3 year warranty

Vibe LED Square Wall Light Surface Mount 3W Black 3K

VBLWL-103-4-3K

Specifications

SKU	VBLWL-103-4-3K
Luminaire efficacy	60 lm/W
EAN	9340994018515
Light Colour	Warm White
Wattage	3.4 W
Lumen output	204 lm
IP rating	65
CRI	80
Beam Angle	95 Degrees
Trim colour	Black
Length	130 mm
Height	130 mm
Lifespan	50000 Hours
Warranty	3 Years
Mounting type	Surface
LED source	Osram Olson
Material	Aluminium Body
Lamp Type	LED
Input voltage	100V - 240V AC
Weatherproof	Weatherproof
Working temperature	-20°C ~ 40°C
Kelvin	3000K



Dimensional Drawings

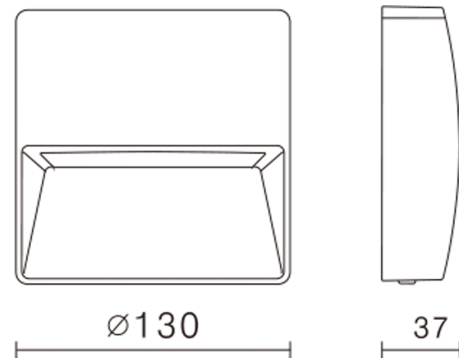

Photometric information available upon request.