



## 202 Series

### VBLUP-202-24V-3K



Our 3W, 3000K, 24V LED In-ground Uplights are a fantastic in-ground path lighting option. With an IP67 rating and IK10 rating, they are ideal in outdoor areas. They can withstand 20KN of static force allowing them to be driven over. With an adjustable internal lens, they can be adapted to meet individual lighting desires to create symmetrical or asymmetrical beam spread. Includes a 50,000 hour lifespan and 5 year warranty.

### Features & Benefits

- 24V in-ground Uplight with 316 Stainless Steel face and die-cast body
- Equipped with 1M of cable and OSRAM LED Chips
- Comes complete with plastic canister for recessing into concrete and is also equipped with spring clips which make them easy to install into decks
- Standard 24° beam angle • IP67 rated
- IK10 able to withstand up to 20KN of static force (able to be driven over) • 50,000 hours lifespan
- 5 year warranty

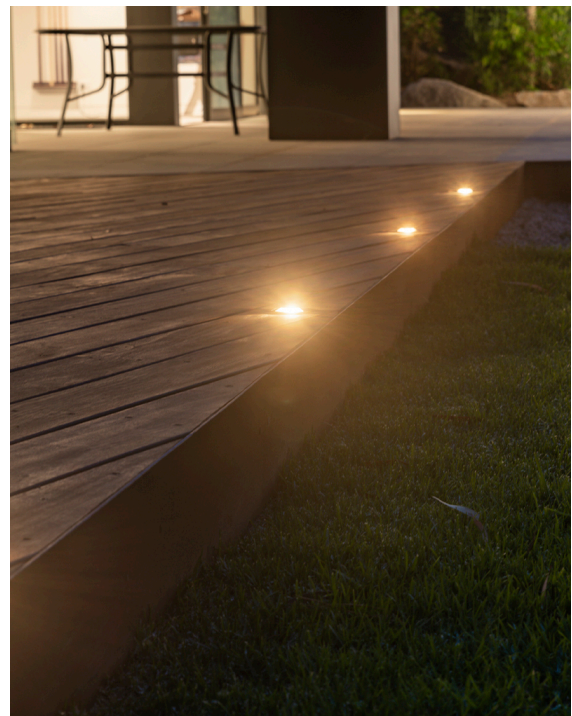

## Specifications

<b>SKU</b>	VBLUP-202-24V-3K
<b>Luminaire efficacy</b>	52 lm/W
<b>EAN</b>	9340994016559
<b>Light Colour</b>	Warm White
<b>Wattage</b>	3 W
<b>Lumen output</b>	157 lm
<b>IP rating</b>	67
<b>IK Rating</b>	10
<b>CRI</b>	80
<b>Beam Angle</b>	24 Degrees
<b>Trim colour</b>	Stainless 316
<b>Diameter</b>	68 mm
<b>Height</b>	108 mm
<b>Lifespan</b>	50000 Hours
<b>Warranty</b>	5 Years
<b>Dimmable</b>	Non-Dimmable
<b>Shatterproof</b>	Shatterproof
<b>Mounting type</b>	Recessed
<b>LED source</b>	Osram Olson
<b>Material</b>	316 Stainless steel front and die-cast body
<b>Accessories</b>	Twin Beam Spread (VBLUP-202-TWIN)
<b>Lamp Type</b>	LED
<b>Input voltage</b>	24 Volt DC
<b>Wiring method</b>	Hardwire
<b>Weatherproof</b>	Weatherproof
<b>Working temperature</b>	-20°C ~ 45°C
<b>Kelvin</b>	3000K



## Dimensional Drawings

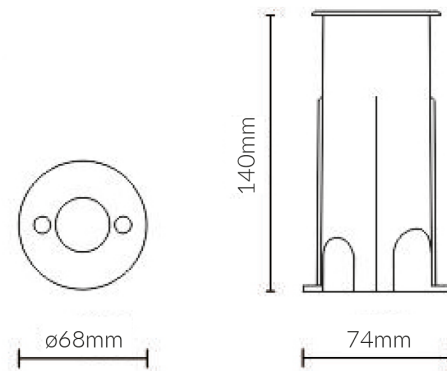

Photometric information available upon request.