



## LED 200 Deck Lights

### VBLUP-200-24V-4K



This Vibe Inground / Uplight /Deck Light is an attractive and tough IP67 lighting solution featuring a stainless steel front cover and die-cast aluminum body. Comes with a 50,000 hour lifespan and a 5 year warranty.

#### Features & Benefits

- 24V in-ground Deck Light with 316 Stainless Steel face and die-cast body
- Equipped with 5M of cable and spring clips which make them easy to install into decks etc.
- IP67 rated
- 50,000 hours lifespan
- 5 year warranty

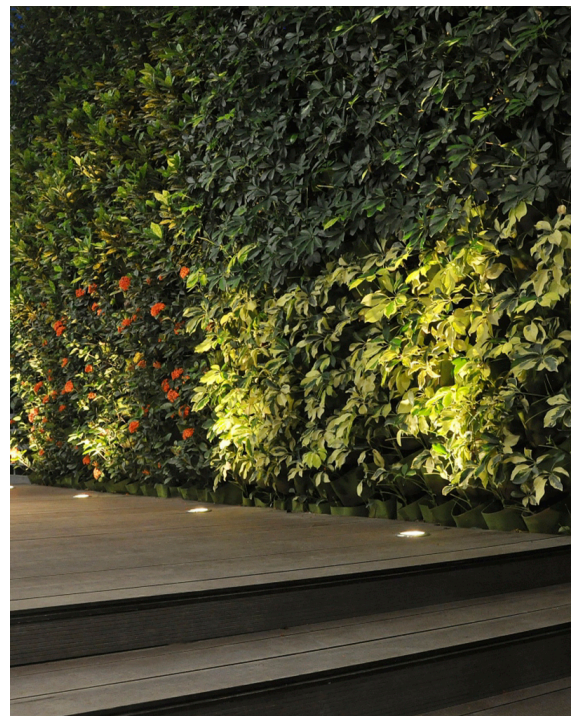

## Specifications

<b>SKU</b>	VBLUP-200-24V-4K
<b>Luminaire efficacy</b>	50 lm/W
<b>EAN</b>	9340994019888
<b>Light Colour</b>	Cool White
<b>Wattage</b>	3 W
<b>Lumen output</b>	150 lm
<b>IP rating</b>	67
<b>CRI</b>	80
<b>Beam Angle</b>	100 Degrees
<b>Trim colour</b>	316 Stainless Steel
<b>Cut out</b>	35mm Diam mm
<b>Diameter</b>	42 mm
<b>Height</b>	90 mm
<b>Lifespan</b>	50000 Hours
<b>Warranty</b>	5 Years
<b>Dimmable</b>	Non-Dimmable
<b>Mounting type</b>	Recessed
<b>LED source</b>	Osram Olson
<b>Material</b>	ADC12 Die-cast Aluminium Housing
<b>Lamp Type</b>	LED
<b>Input voltage</b>	24 Volt DC
<b>Diffuser</b>	Frosted
<b>Wiring method</b>	Hardwire
<b>Weatherproof</b>	Weatherproof
<b>Working temperature</b>	-20°C ~ 50°C
<b>Kelvin</b>	4000K



## Dimensional Drawings

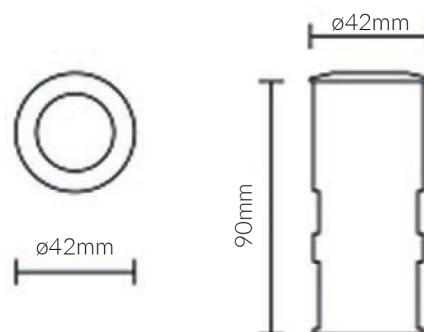

Photometric information available upon request.