

# Double Head Post Light



62x SMD LEDs  
@ 0.2w each



6x 2800mAh  
NiMH Batteries



6W Built-In  
Solar Panel



Dust & Water  
Protection



Aluminium Alloy  
Construction



700 Lumens at 1  
metre

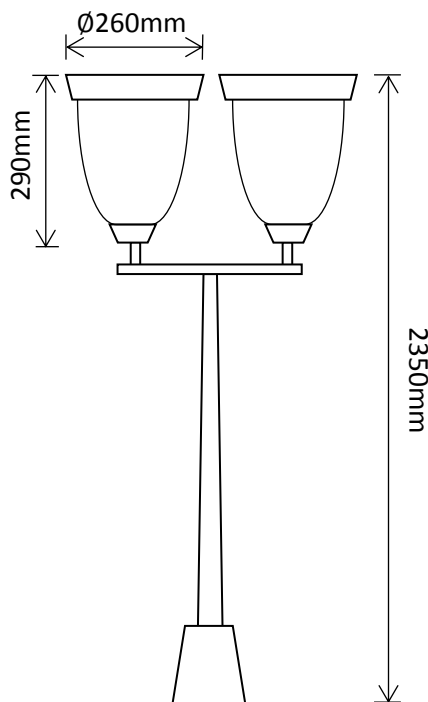
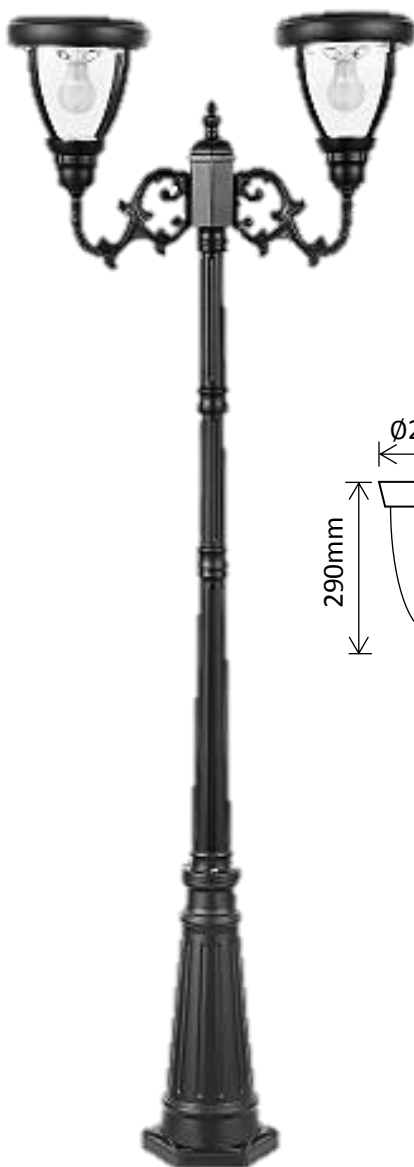

## SLDPL0007B-12.4W

### Features:

- Built in Photo Electric Cell
- High/Low Setting
- 8-10 hours Operation per day
- Tapered Aluminium Post
- Decorative Mounting Base
- Black Powder Coated
- Glass Lampshade

