

Floor Lite

Cat. No. FL
 Cat. No. FLFL
 Cat. No. FLGU
 Cat. No. FLMH20
 Cat. No. FLMH35

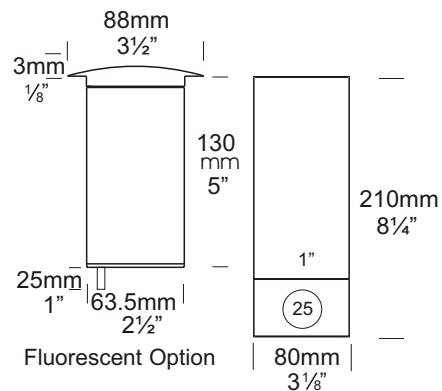

Fluorescent Canister (PVC)
 (Supplied with Luminaire)

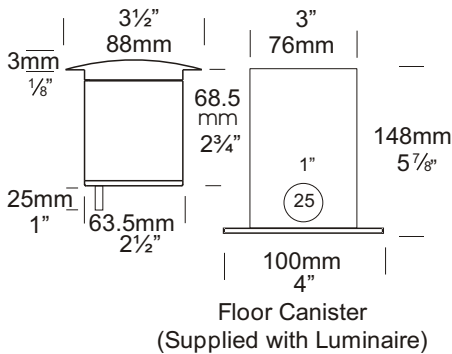
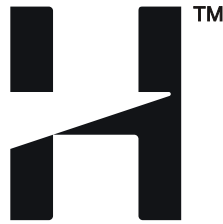
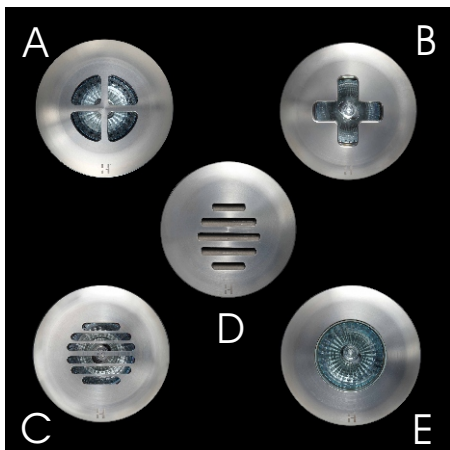

The Floor Lite has an extremely low profile (3mm) and can be walked upon without damaging the luminaire. There are five flange designs: Clover, Grill, Louvre (45 degree angle), Spot, Cross and is supplied with a mounting canister.

This luminaire is available in 316 stainless steel. The Floor Lite Spot is also available in copper.

A 110/240 volt fluorescent option is available which offers excellent light output, low energy usage and very low heat generation, this changes the luminaire to an IP66 rating.

A GU10 version of this luminaire is also available for line voltage lamps. The Floor Lite Metal Halide is extremely energy efficient, outputting 2-3 times the light of a halogen lamp, and uses a GX10 20 or 35 watt lamp. The Metal Halide version is not UL or CSA approved for use in the USA or Canada.

Ordering Information

Luminaire Type	Material	Accessories						
FL - Floor Lite	SS - 316 Stainless Steel	CJK150 - Cable Joint Kit Canss - 316 Stainless Steel Canister LENSSTEPF - Frost Lens Dkcan - Deck Canister FLcan - Floor Lite Canister FL - Fluorescent Option GU - GU10 Option MH - Metal Halide Option Flucan - Fluorescent Canister HCL - Hex Cell Adaptor						
<table border="1"> <thead> <tr> <th>Flange</th> </tr> </thead> <tbody> <tr> <td>CL - Clover (A)</td> </tr> <tr> <td>CR - Cross (B)</td> </tr> <tr> <td>GR - Grill (C)</td> </tr> <tr> <td>LU - Louvre (D)</td> </tr> <tr> <td>SP - Spot (E)</td> </tr> </tbody> </table>			Flange	CL - Clover (A)	CR - Cross (B)	GR - Grill (C)	LU - Louvre (D)	SP - Spot (E)
Flange								
CL - Clover (A)								
CR - Cross (B)								
GR - Grill (C)								
LU - Louvre (D)								
SP - Spot (E)								
For LED options, refer to page 10.4 (dedicated LED), 10.4.3 (6 watt), 10.4.4 (3 watt) or http://hunza.co.nz/l.html								

Ordering Example: FLLU SS - Floor Lite Louvre (D)
 316 Stainless Steel

FLSPFL SS - Floor Lite in 316 Stainless Steel
 Spot (E) with fluorescent option

FLSPGU SS - Floor Lite Spot (E) GU10
 in 316 Stainless Steel

FLSPMH20 SS - Floor Lite Spot (E) Metal Halide
 20 watt in 316 Stainless Steel
 (Accessories ordered separately)

HUNZA™ PURE OUTDOOR LIGHTING

HUNZA FACTORY
 130 Felton Mathew Ave
 Glen Innes
 Auckland 1072
 New Zealand

Ph: 64-9-528 9471
 Fax: 64-9-528 9361
hunza@hunza.co.nz
www.hunza.co.nz

INTERNATIONAL CONTACTS:
www.hunza.co.nz/contacts.php

Specifications may change without notice.
 Manufactured in New Zealand.
 © 2011 Hunza Holdings Ltd.

Ver 1.4

Luminaire Construction

CNC machined from:

Body:

316 Stainless Steel 63.5mm (2½") x 9mm (11/32"). End cap - solid 316 stainless steel 63.5mm (2½") rod.

Flange:

316 Stainless Steel 90mm (3½").

Mounting

The luminaire is pushed into the canister and is held by two silicone "O" rings: Canss, FLcan, Flucan: Cast into concrete, brick, concrete block, etc.

Dkcan: mounted into wooden decks, wooden frames, etc.

Features

Lens:

3mm (1/8") clear tempered shatter resistant glass.

Lifetime Warranty.

Gasket:

Silicone, iron impregnated 220°C (428°F).

Lamp Holders:

GU5.3 & GU10 - 350°C (662°F) ceramic multi contact lamp holder with 250°C (480°F) teflon cables.

Metal Halide GX10 - 350°C (662°F) ceramic multi contact lamp holder with 250°C (480°F) teflon cables.

Fluorescent:

E27 PET 210°C (410°F) base mount. E26 available in the USA.

Accessories:

Cable Joint Kit (Cat. CJK150)
Not approved for USA /Canada.

Deck Canister (Cat. Dkcan).

Frosted Lens (Cat. LENSSTEPF).

Floor Canister (Cat. FLcan).

Fluorescent Canister PVC (Cat. Flucan).

Fluorescent Option 8watt 240 volt (Cat. FL) IP66. (Note: Not for USA/Canada).

GU10 Option (Cat. GU).

Metal Halide Option (Cat. MH).

Hex Cell Louvre Adaptor (Cat. HCL)
(Note: Supplied as standard for USA/Canada).

316 Stainless Canister for use in lime stone etc. (Cat. Canss).

Standards

EN60598

IP66/IP68



UL1838

Luminaire Weight

SS .995kg (2lb 3oz)

Fluorescent IP66

SS 1.630kg (3lb 10oz)

Power Supply

HUNZA™ Inground or Wall Mount
Transformer: not included.

Metal Halide - 230-240 volt ac 50Hz
remote inground ballast with
waterproof inground housing

USA and Canada:

HUNZA™ Wall Mount Transformer:
not included.

Metal Halide Version not UL or
CSA approved for use in USA/Canada.

Luminaire: supplied with

MR16 GU5.3 - 20 watt lamp max.

GU10 - GU10 25 or 35 watt lamp max.

LED - Refer to previous page.

Metal Halide - GX10 20 or 35 watt lamp

Fluorescent

E27 - 110/240 volt self ballasted lamp.

USA and Canada

MR16 GU5.3 20 watt lamp max.

GU10 Halogen - Lamp not supplied

LED - Refer to previous page.

Metal Halide version not UL or
CSA approved for use in USA/Canada.

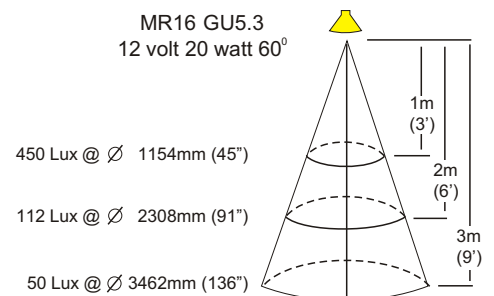
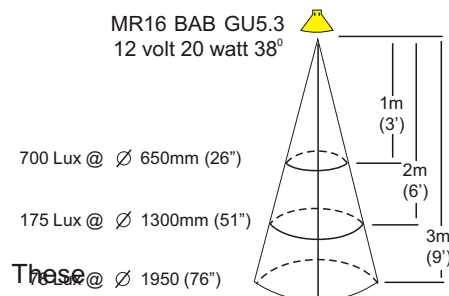
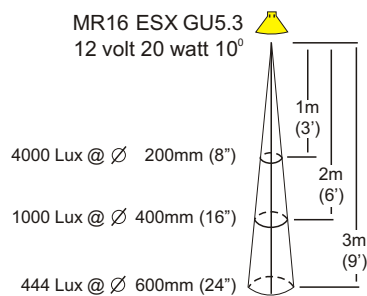

diagrams refer to the Spot Lite Flange (D) only.

HUNZA™ PURE
OUTDOOR
LIGHTING

HUNZA FACTORY
130 Felton Mathew Ave
Glen Innes
Auckland 1072
New Zealand

Ph: 64-9-528 9471
Fax: 64-9-528 9361
hunza@hunza.co.nz
www.hunza.co.nz

INTERNATIONAL CONTACTS:
www.hunza.co.nz/contacts.php

Specifications may change without notice.
Manufactured in New Zealand.
© 2011 Hunza Holdings Ltd.

Ver 1.4