



PRODUCT ORDERING

LED STRIP CONTROLLER	
	HCP-75232
COMPATIBLE REEIVER	COMPATIBLE DMX DECODER
HCP-76241 	HCP-73231

PRODUCT DATA

RGBW TOUCH PANEL	
MATERIAL	PLASTIC + GLASS
COLOUR/FINISH	WHITE
LED STRIP TYPE	RGBW
NO. OF CHANNELS	N/A
INPUT VOLTAGE	240V AC
OUTPUT SIGNAL	2.4GHZ + DMX512
DIMMING	YES
DIMMING RANGE	5% - 100%
PROTECTION	OVERLOAD & SHORT CIRCUIT
WORKING TEMP	-30°C - 55°C
WEIGHT	165G

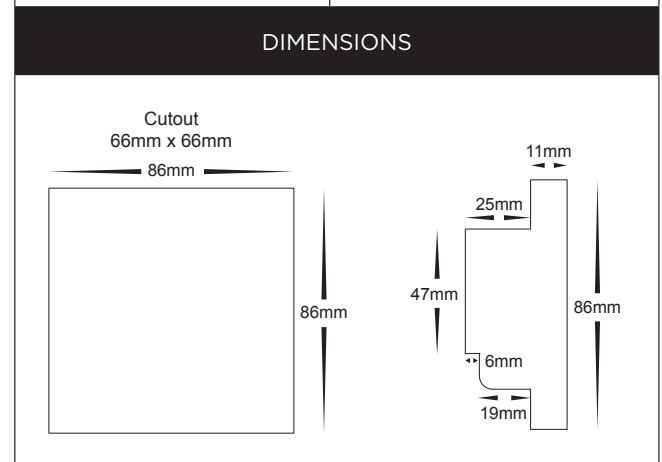

SAMPLE WIRING DIAGRAM

