

100w 24v DC Dali Dimmable Weatherproof LED Driver

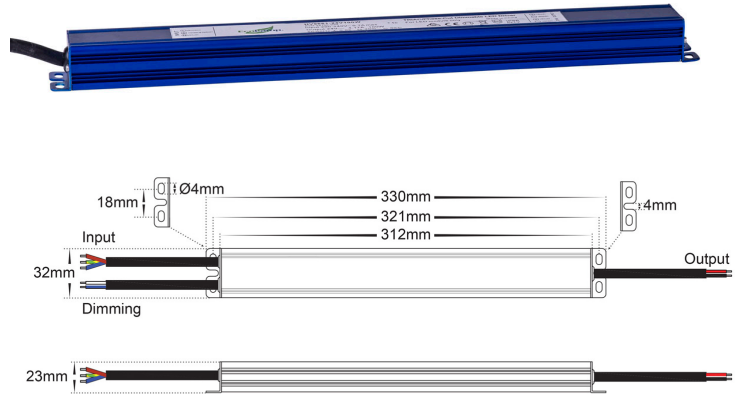

PRODUCT SPECIFICATIONS

| | |
|--------------------------|-------------------------------------|
| MATERIAL | Aluminium |
| COLOUR/FINISH | Blue |
| WORKING TEMPERATURE | -40C to +60°C |
| OVERLOAD PROTECTION | Yes |
| SHORT CIRCUIT PROTECTION | Yes |
| OVER VOLTAGE PROTECTION | Yes |
| DIMMING | Dali Dimmable |
| INPUT VOLTAGE | 240v AC (Supplied with flex & plug) |
| OUTPUT VOLTAGE | 24v DC Constant Voltage |
| RECOMMENDED MAX. LOAD | 80w |
| IP RATING | IP66 |
| WARRANTY | 5 Years Replacement |



TECHNICAL SPECIFICATIONS

| | | |
|-------------------------|--------------------------------|---|
| PART NUMBER: | | HCP-52243 |
| OUTPUT | DC Voltage | 24V |
| | Voltage Tolerance | ±0.5V |
| | Voltage Regulation | ± 0.5% |
| | Rated current | 4.17A |
| | Rated power | 100W (Recommended Maximum Load = 80w) |
| | Load Regulation | ± 1% |
| INPUT | Voltage Range | 200-240VA |
| | Frequency Range | 47 - 63Hz |
| | Power Factor(Typ.)@ full load | PF≥0.97/230VAC |
| | THD(Typ.) @ full load | < 20% |
| | Efficiency(Typ.)@ full load | 83% |
| | AC Current(Max.) | 0.8A |
| | Inrush Current (Typ.) | 49.5A,50%,490us |
| | Leakage current | <0.5mA |
| PROTECTION | Short Circuit | shut down o/p voltage, re-power on to recover after fault condition is removed |
| | Over Load/ Over temperature | ≤120% constant current limiting, recover automatically after fault condition is removed 100°C±10°C |
| | Protection Class | II |
| ENVIRONMENT | Working TEMP. | -40-+60°C |
| | Working Humidity | 20 - 95%RH,non-condensing |
| | Storage TEM.,Humidity | -40 - +80°C,10 - 95%RH |
| | TEMP.coefficient | ±0.03%/°C(0 - 50°C) |
| | Vibration | 10~500Hz, 5G 10min./1 cycle,period for 60min. each along X,Y,Z axes |
| SAFETY & EMC | Safety standards | EN61347-1 EN61347-2-13 EN62493 IP66 |
| | Withstand voltage | I/P-O/P:3.75KVAC I/P-FG:1.88KVAC O/P-FG:0.5KVAC |
| | Isolation resistance | I/P-O/P I/P-FG O/P-FG: 100MΩ/500VDC/25°C/70%RH |
| | EMC Emission | EN55015 EN61000-3-2 EN61000-3-3 |
| | EMC Immunity | EN61000-4-2,3,4,5,6,11 EN61547 |
| OTHERS | Net Weight | 0.55Kg |
| | Dimension | 330*32*23mm(L*W*H) |
| | Warranty | 5 Years Replacement |