

60w 24v DC Dali Dimmable Weatherproof LED Driver

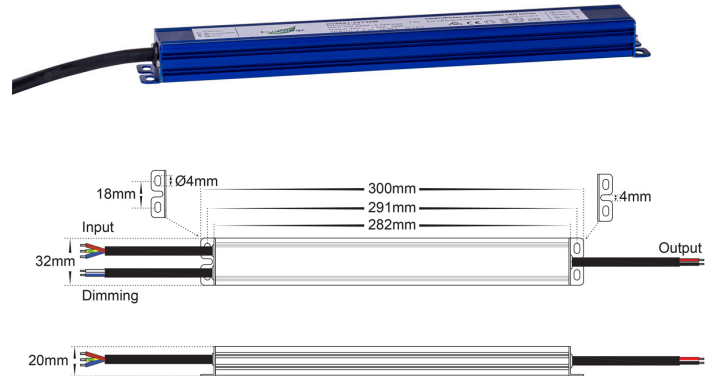

PRODUCT SPECIFICATIONS

MATERIAL	Aluminium
COLOUR/FINISH	Blue
WORKING TEMPERATURE	-40C to +60°C
OVERLOAD PROTECTION	Yes
SHORT CIRCUIT PROTECTION	Yes
OVER VOLTAGE PROTECTION	Yes
DIMMING	Dali Dimmable
INPUT VOLTAGE	240v AC (Supplied with flex & plug)
OUTPUT VOLTAGE	24v DC Constant Voltage
RECOMMENDED MAX. LOAD	48w
IP RATING	IP66
WARRANTY	5 Years Replacement



TECHNICAL SPECIFICATIONS

PART NUMBER:		HCP-52233
OUTPUT	DC Voltage	24V
	Voltage Tolerance	±0.5V
	Voltage Regulation	±0.5%
	Rated current	2.5A
	Rated power	60W (Recommended Maximum Load = 48w)
	Load Regulation	±1.5 %
INPUT	Voltage Range	200-240VAC
	Frequency Range	47 - 63Hz
	Power Factor(Typ.)@ full load	PF≥0.97/230VAC
	THD(Typ.) @ full load	<20%
	Efficiency(Typ.)@ full load	85%
	AC Current(Max.)	0.5A
	Inrush Current (Typ.)	50A,50%,176us
	Leakage current	<0.5mA
PROTECTION	Short Circuit	shut down o/p voltage, re-power on to recover after fault condition is removed
	Over Load	≤120% Hiccup mode,recovers automatically after fault condition is removed
	Over temperature	100°C±10°C
	Protection Class	II
ENVIRONMENT	Working TEMP.	-40-+60°C
	Working Humidity	20 - 95% RH,non-condensing
	Storage TEM.,Humidity	-40 - +80°C, 10 - 95%RH
	TEMP.coefficient	±0.03%/°C(0 - 50°C)
	Vibration	10~500Hz, 5G 10min./1 cycle,period for 60min. each along X,Y,Z axes
SAFETY & EMC	Safety standards	EN61347-1 EN61347-2-13 EN62493 IP66
	Withstand voltage	I/P-O/P:3.75KVAC I/P-FG:1.88KVAC O/P-FG:0.5KVAC
	Isolation resistance	I/P-O/P I/P-FG O/P-FG: 100MΩ/500VDC/25°C/70%RH
	EMC Emission	EN55015 EN61000-3-2 EN61000-3-3
	EMC Immunity	EN61000-4-2,3,4,5,6,11 EN61547
OTHERS	Net Weight	0.4Kg
	Dimension	300*32*20mm(L*W*H)
	Warranty	5 years replacement