

CELL-17-D90 LED Downlight



Description

The CELL 17 D90 KIT are a plug and play LED lamp module and LED driver set. They are the perfect solution for residential homes to commercial projects such as hotels, clubs, pubs and bars. Designed not only as a replacement for traditional halogen lamps in most applications, but also as a replaceable LED lamp and driver set for a range of click in frames, as a complete downlight solution. For retrofit, it's as easy as removing the standard MR16 halogen lamp and transformer and replacing it with the CELL lamp and LED driver. It suits most MR16 downlight frames, depending on height.

As a complete lamp and frame solution, simply choose from a range of click in frames on offer to suit the style and décor. Featuring a reflector style lens with a choice of 15°, 24°, 36° or 60° beam angle effects to suit ceiling heights or lighting effects. Available as a 17W complete with dimmable LED driver and flex and plug. Backed by our Three Year Replacement Warranty.

Specification Features

- Input Voltage: 200-240V 50-60HZ
- Power (W): 17
- IP rating (IP): IP44*
- Lumens (lm): Extra Warm White 2700K - 1500lm
Warm White 3000K - 1550lm
Neutral White 4000K - 1650lm
White 5000K - 1700lm
- LED type: COB
- CCT: 2700K - 3000K - 4000K - 5000K
- CRI: ≥80
- Beam angle (°): 60°
- Dimmable: Yes
- Lifespan (hrs): 50,000hrs

* IP44 rating is from the underside of the down light once installed into the ceiling.

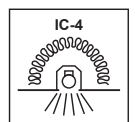

Diagrams / Additional

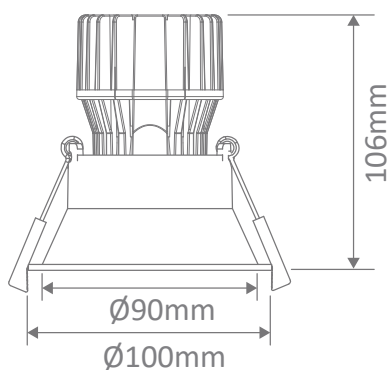

Cutout: Ø90-92mm

Item No.	Variant		CCT
	Wht	Blk	
CELL-17-D90	21690	21691	2700K
	21696	21697	3000K
	21702	21703	4000K
	21708	21709	5000K